

DESIGN NOTES

3V and 5V 12-Bit Rail-to-Rail Micropower DACs Combine Flexibility and Performance – Design Note 127

Roger Zemke and Hassan Malik

The LTC[®]1450 and LTC1450L are complete single supply rail-to-rail voltage output, 12-bit DACs in 24-pin SSOP and PDIP packages. They include an output buffer amplifier, a reference and a double-buffered parallel digital interface. These DACs use a proprietary architecture which guarantees a maximum DNL error of 0.5LSB. A built-in power-on reset ensures that the output of the DAC is initialized to zero scale.

The rail-to-rail buffered output can source or sink 5mA while pulling to within 300mV of the positive supply voltage or ground. The output swings to within a few millivolts of either supply rail when unloaded and has an equivalent output resistance of 40Ω when driving a load to the rails.

Low Power, 5V or 3V Single Supply Operation

The LTC1450 draws only 400μA from a 4.5V to 5.5V supply. The DAC can be configured for a 0V to 4.095V or 0V to 2.048V output range. It has a 2.048V internal reference.

The LTC1450L draws 250μA from a 2.7V to 5.5V supply. It can be configured for a 0V to 2.5V or 0V to 1.22V output range. It has a 1.22V internal reference.

Flexibility with Stand-Alone Performance

The LTC1450/LTC1450L are complete stand-alone DACs requiring no external components. Reference output, reference input and gain setting pins provide the user with added flexibility.

Figure 1 shows how these DACs may typically be used. REF HI is tied to REF OUT and REF LO and X1/X2 are grounded.

4-Quadrant Multiplying DAC Application

Figure 2 shows the LTC1450L configured as a single supply 4-quadrant multiplying DAC. It uses a 5V supply and only one external component, a 5k resistor tied from REF OUT to ground. (The LTC1450 can be used in a similar fashion.) The

LT, LTC and LT are registered trademarks of Linear Technology Corporation.

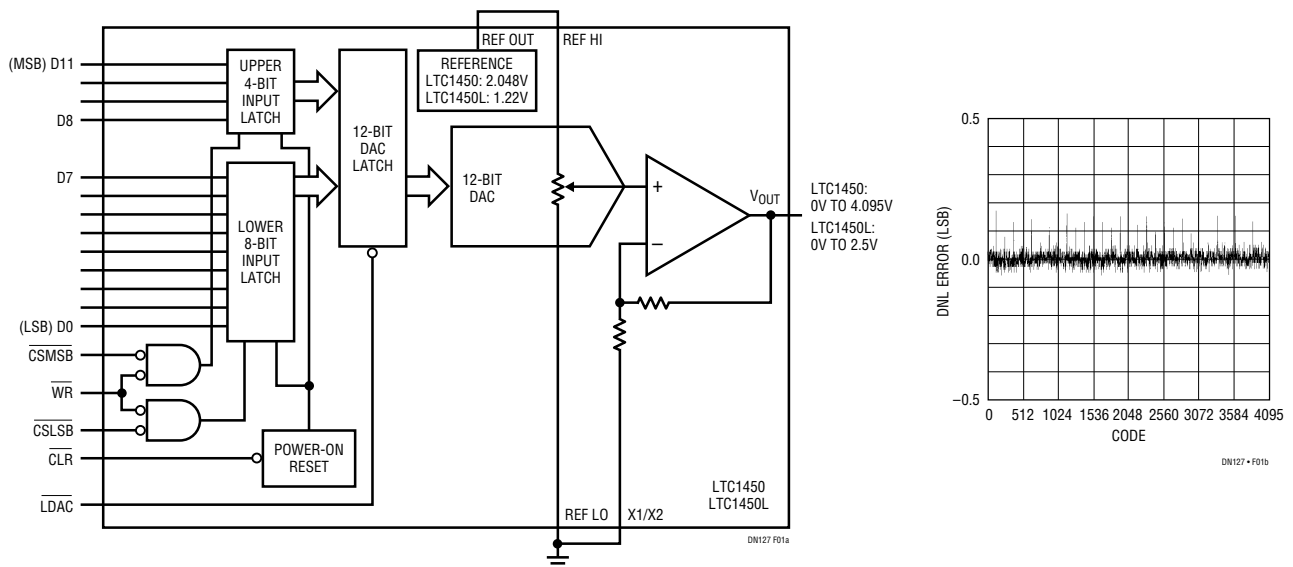

Figure 1. Byte/Parallel Input, Internal/External Reference, Power-On Reset and Gain Select Provide Application Flexibility. The Patented Architecture Guarantees Excellent DNL

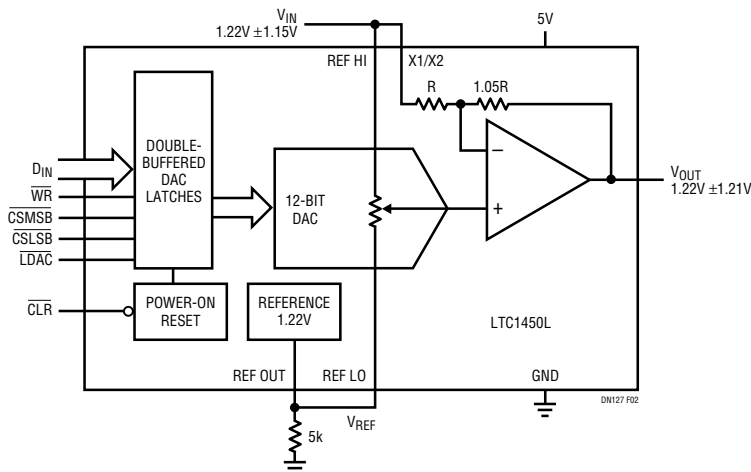

Figure 2. Internal Reference, REF LO/REF HI Pins, Gain Adjust and Wide Supply Voltage Range Allow 4-Quadrant Multiplying on a 5V Single Supply

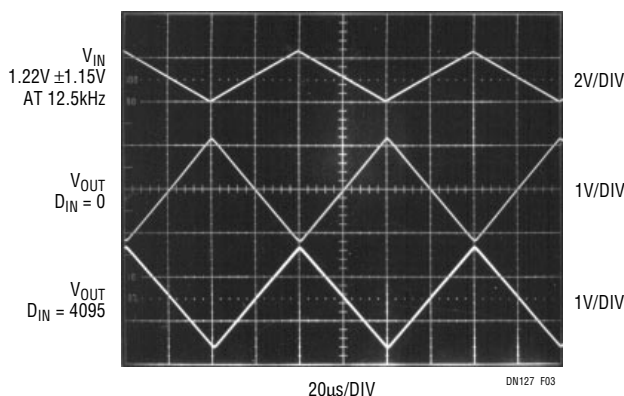

Figure 3. Clean 4-Quadrant Multiplying Is Shown in the Output Waveforms for Zero-Scale and Full-Scale DAC Settings

multiplying DAC allows the user to digitally change the amplitude and polarity of an AC input signal whose voltage is centered around an offset signal ground provided by the 1.22V reference voltage. The transfer function is shown in the following equations.

$$V_{OUT} = (V_{IN} - V_{REF}) \left[\text{Gain} \left(\frac{D_{IN}}{4096} - 1 \right) + 1 \right] + V_{REF}$$

For the LTC1450L Gain = 2.05 and $V_{REF} = 1.22V$

$$V_{OUT} = (V_{IN} - 1.22V) \left[2.05 \left(\frac{D_{IN}}{4096} \right) - 1.05 \right] + 1.22V$$

Table 1 shows the expressions for V_{OUT} as a function of V_{IN} , V_{REF} and D_{IN} . Figure 3 shows a 12.5kHz, 2.3V_{P-P} triangle wave input signal and the corresponding output waveforms for zero-scale and full-scale DAC codes.

Table 1. Binary Code Table for 4-Quadrant, Multiplying DAC Application

BINARY DIGITAL INPUT CODE IN DAC REGISTER		ANALOG OUTPUT (V_{OUT})
MSB	LSB	
1111	1111	$(4094/4096)(V_{IN} - V_{REF}) + V_{REF}$
1100	0001	$0.5(V_{IN} - V_{REF}) + V_{REF}$
1000	0011	V_{REF}
0100	0100	$-0.5(V_{IN} - V_{REF}) + V_{REF}$
0000	0110	$-1.0(V_{IN} - V_{REF}) + V_{REF}$
0000	0000	$-1.05(V_{IN} - V_{REF}) + V_{REF}$

For literature on our D/A Converters, call **1-800-4-LINEAR**. For applications help, call (408) 432-1900, Ext. 456